



## A5A:670.XX

### VOLTAGE RATINGS

Part Number	$V_{RRM}, V_R$ (V) Max. rep. peak reverse voltage		$V_{RSM}, V_R$ (V) Max. non-rep. peak reverse voltage
	$T_J = 0$ to $180^\circ\text{C}$	$T_J = -40$ to $0^\circ\text{C}$	$T_J = 25$ to $180^\circ\text{C}$
	A5A:670.02	200	200
A5A:670.04	400	400	500
A5A:670.06	600	600	700
A5A:670.08	800	800	900
A5A:670.10	1000	1000	1100
A5A:670.12	1200	1200	1300

### MAXIMUM ALLOWABLE RATINGS

PARAMETER	VALUE	UNITS	NOTES
$T_J$ Junction Temperature	-40 to 180	$^\circ\text{C}$	-
$T_{stg}$ Storage Temperature	-40 to 180	$^\circ\text{C}$	-
$I_{F(AV)}$ Max. Av. current @ Max. $T_C$	550	A	180° half sine wave
	125	$^\circ\text{C}$	
$I_{F(RMS)}$ Nom. RMS current	1060	A	-
$I_{FSM}$ Max. Peak non-rep. surge current	7.65	kA	50 Hz half cycle sine wave Initial $T_J = 180^\circ\text{C}$ , rated $V_{RRM}$ applied after surge.
	8.00		60 Hz half cycle sine wave
	9.10		50 Hz half cycle sine wave Initial $T_J = 180^\circ\text{C}$ , no voltage applied after surge.
	9.50		60 Hz half cycle sine wave
$I^2t$ Max. $I^2t$ capability	267	$\text{kA}^2\text{s}$	$t = 10\text{ms}$ Initial $T_J = 180^\circ\text{C}$ , rated $V_{RRM}$ applied after surge.
	292		$t = 8.3\text{ms}$
	378		$t = 10\text{ms}$ Initial $T_J = 180^\circ\text{C}$ , no voltage applied after surge.
	414		$t = 8.3\text{ms}$
$I^2t^{1/2}$ Max. $I^2t^{1/2}$ capability	4140	$\text{kA}^2\text{s}^{1/2}$	Initial $T_J = 180^\circ\text{C}$ , no voltage applied after surge. for time $t_x = I^2t^{1/2} * t_x^{1/2}$ . ( $0.1 < t_x < 10\text{ms}$ ). $\hat{I}t$
F Mounting Force	450	N.m	-



# A5A:670.XX

## CHARACTERISTICS

PARAMETER	MIN.	TYP.	MAX.	UNITS	TEST CONDITIONS
V <sub>FM</sub> Peak forward voltage	---	1.50	1.67	V	Initial T <sub>J</sub> = 25°C, 50-60Hz half sine, I <sub>peak</sub> = 1728A.
V <sub>F(TO)1</sub> Low-level threshold	---	---	0.782	V	T <sub>J</sub> = 180°C
V <sub>F(TO)2</sub> High-level threshold	---	---	0.859		Av. power = V <sub>F(TO)</sub> * I <sub>F(AV)</sub> + r <sub>F</sub> * [I <sub>F(RMS)</sub> ] <sup>2</sup>
r <sub>F1</sub> Low-level resistance	---	---	0.541	m	Use low values for I <sub>FM</sub> < I <sub>F(AV)</sub>
r <sub>F2</sub> High-level resistance	---	---	0.470		
I <sub>RM</sub> Peak reverse current	---	13	30	mA	T <sub>J</sub> = 180°C. Max. Rated VRRM
R <sub>thJC</sub> Thermal resistance, junction-to-case	---	---	0.080	°C/W	DC operation, double side
	---	---	0.092	°C/W	180° sine wave, double side
	---	---	0.094	°C/W	120° rectangular wave, duble side
R <sub>thCS</sub> Thermal resistance, case-to-sink	---	---	0.03	°C/W	Mtg. Surface smooth, flat and greased.
wt Weight	---	57(2.0)	---	g(oz.)	---
Case Style	DO-200AA			JEDEC	---

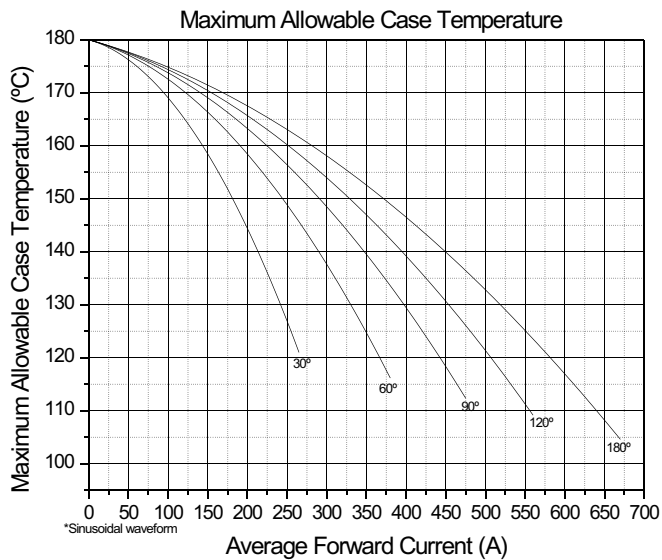

Fig. 1 - Current Ratings Characteristics

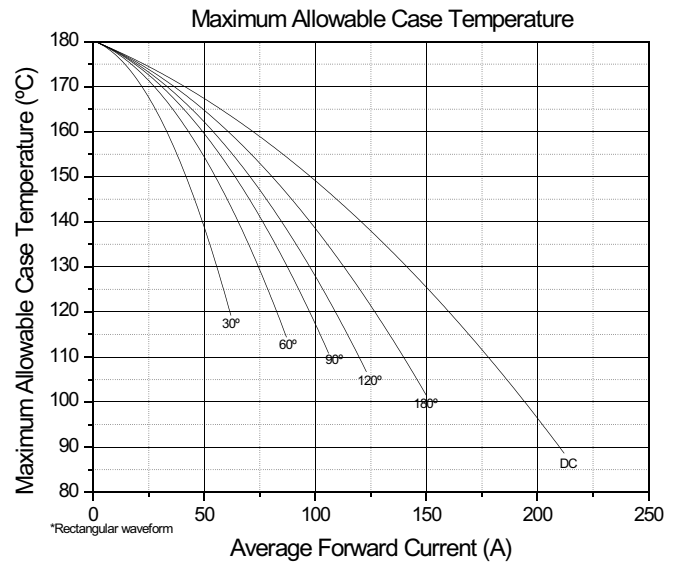

Fig. 2 - Current Ratings Characteristics



## A5A:670.XX

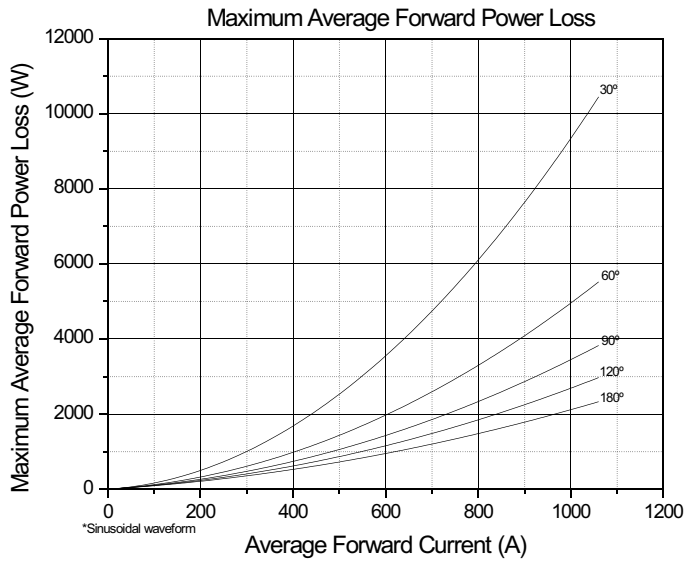

Fig. 3 - On-State Power Loss Characteristics

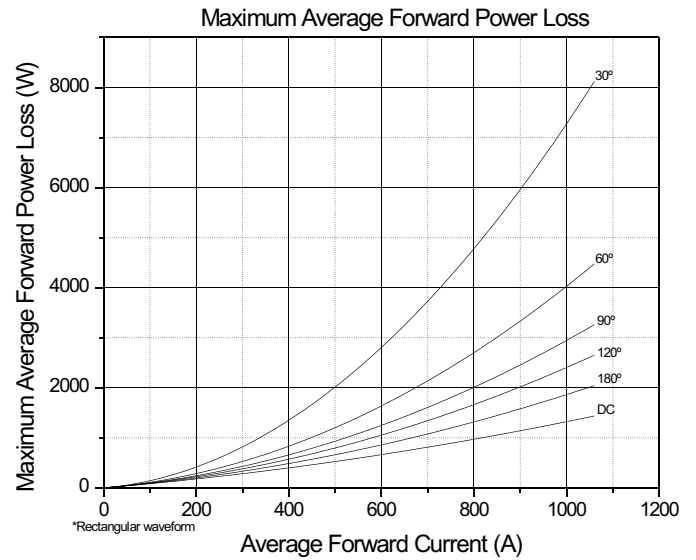

Fig. 4 - On-State Power Loss Characteristics

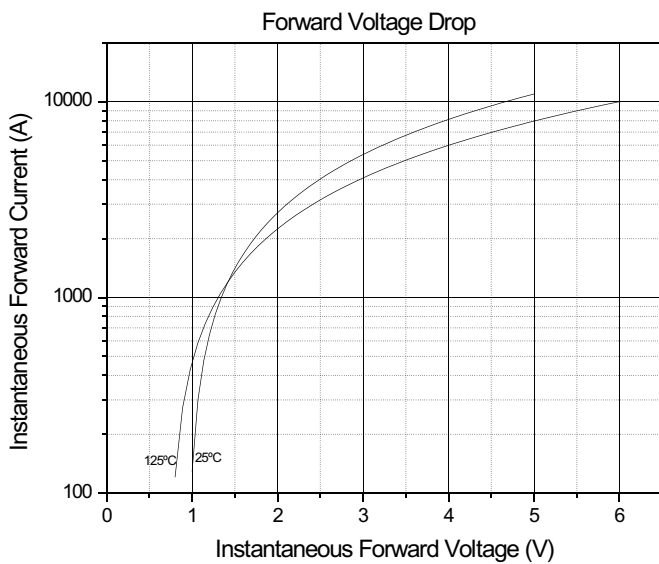

Fig. 5 - Forward Voltage Drop Characteristics

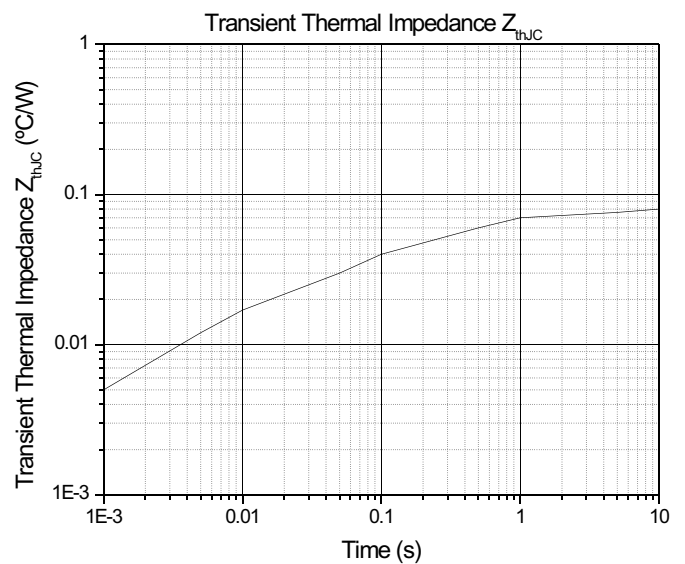
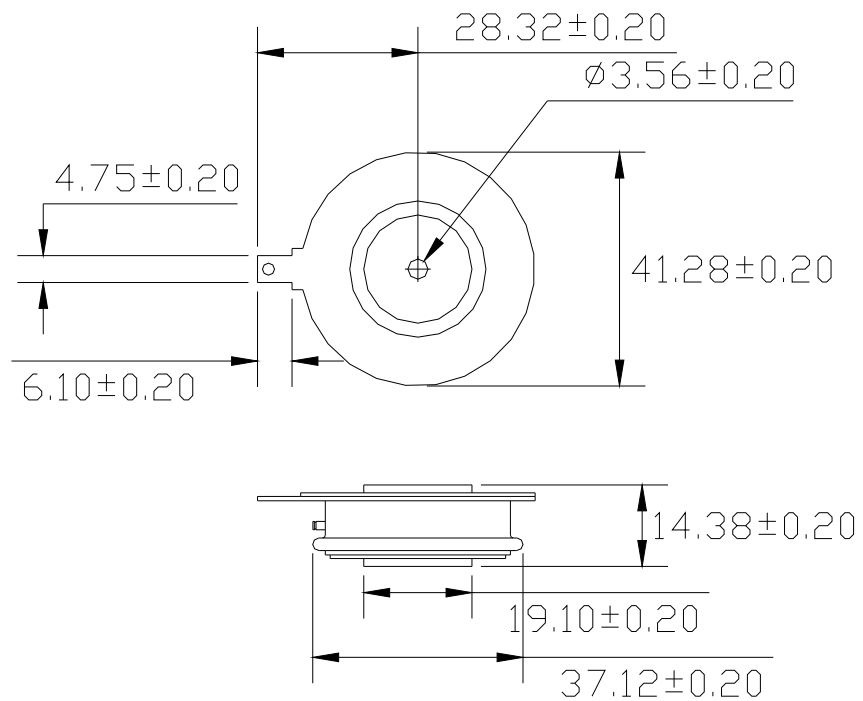

Fig. 6 - Transient Thermal Impedance Characteristics



**A5A:670.XX**

**TO-200AA**



**Fig. 7 - Outline Characteristics**